

WM-1 TYPE GATE VALVE

Description

WM-1 gate valves feature a rising balanced stem with an expanding gate design to provide safe dependable service in a variety of environments. It is available in flanged ends in standard bore sizes from 1 13/16" thru 4 1/4" in 10,000 psi working pressures.

WM-1 gate valves come in 7 1/16" with working pressures of 10,000 psi. WM-1 gate valves with different working pressure specifications available upon request.

Full-Bore Thru-Conduit Design

- Maximizes valve service life.

Expanding Gate

- Creates a positive mechanical seal across the seats with or without line pressure.
- Isolates the body cavity from bore pressure in both the open and closed position.

Metal-to-Metal Seals

- Body/bonnet interface and gate/seat interface.

In-line Repairability

- Stem packing is re-energized while the valve is under pressure.

Long Life, Low Maintenance

- Simple routine maintenance program limits repairs, eases operation, protects against corrosion, and extends service life.

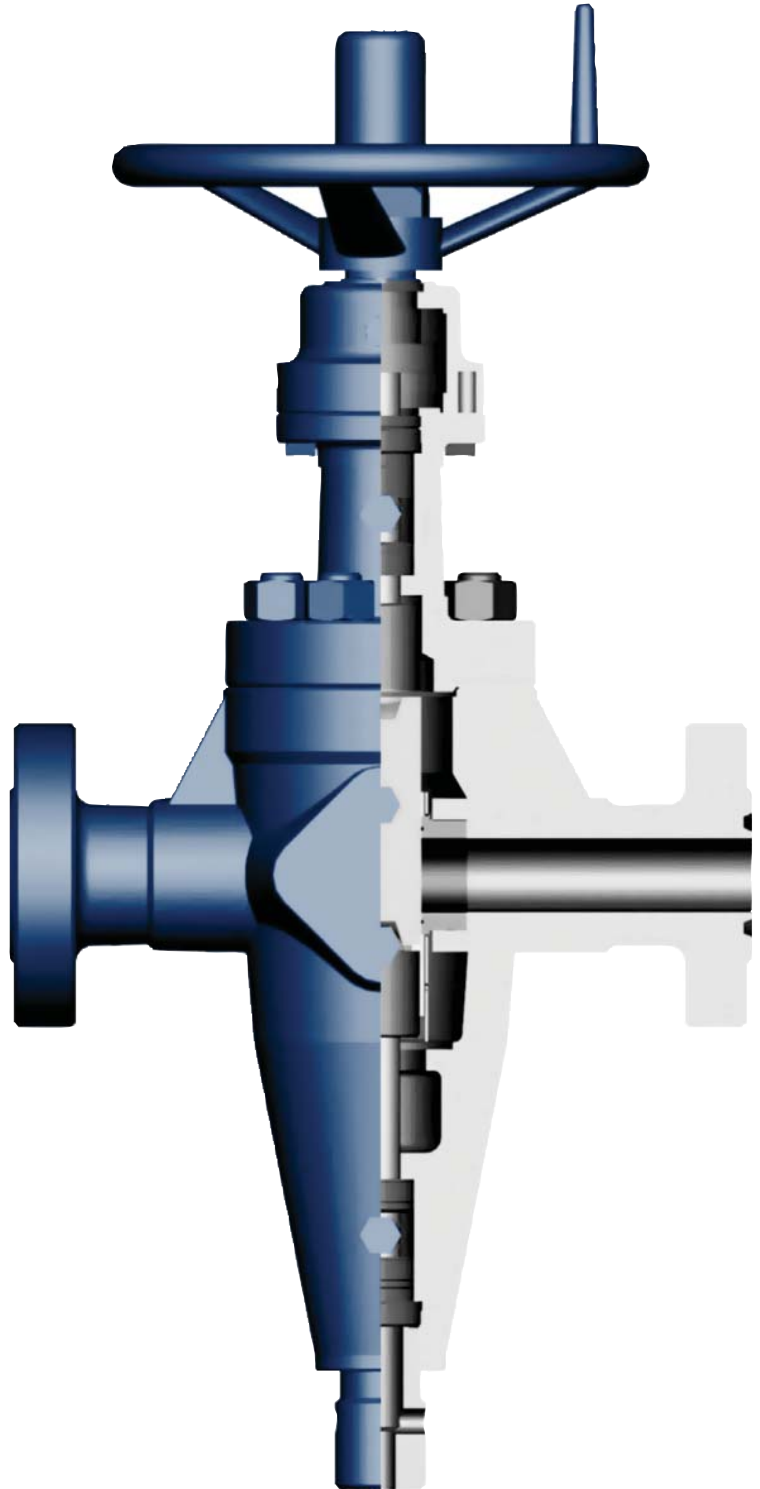

Company

Services

CT Completions

CT Surface

CT Sub-Surface

CT Service Tools

Wellheads

Slickline

Engineering Data

Index

WM-1 TYPE GATE VALVE

10,000 psi

Flange Size	A	B	C	D	Approximate Weight (lbs)
1 1/16"	18.25"	14.50"	21.00"	14"	252
2 1/16"	20.50"	15.62"	23.50"	19"	344
2 9/16"	22.25"	18.00"	25.88"	19"	502

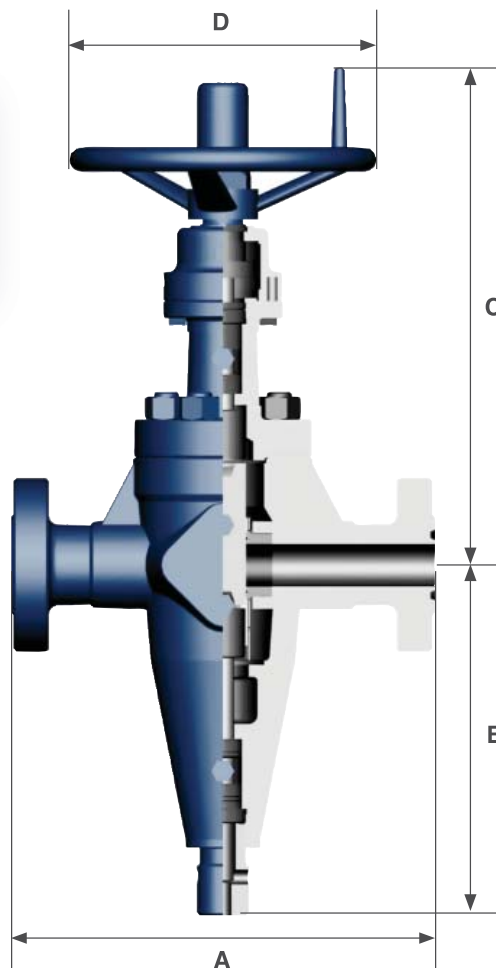

Trim Chart

Service Condition	Material Class	Body	Bonnet	Gate	Seat	Stem
General Oilfield Gas, Oil	AA	Alloy	CS	4130	4130	4130
General Slightly Corrosive	BB	Alloy	Alloy	410 SS Hardfaced	410 SS Hardfaced	17-4PH
General Moderately Corrosive CO ₂	CC	410 SS	410 SS	410 SS Hardfaced	410 SS Hardfaced	17-4PH
Sour Non-Corrosive	DD	Alloy	Alloy	Alloy	Alloy	17-4PH
Sour Slightly Corrosive	EE	Alloy	Alloy	410 SS Hardfaced	410 SS Hardfaced	17-4PH
Sour Moderately Corrosive H ₂ S	FF	410 SS	410 SS	410 SS Hardfaced	410 SS Hardfaced	17-4PH

Valve trims currently available are DD, EE, and FF. Additional trims available upon request.